

Absolute encoder Multiturn

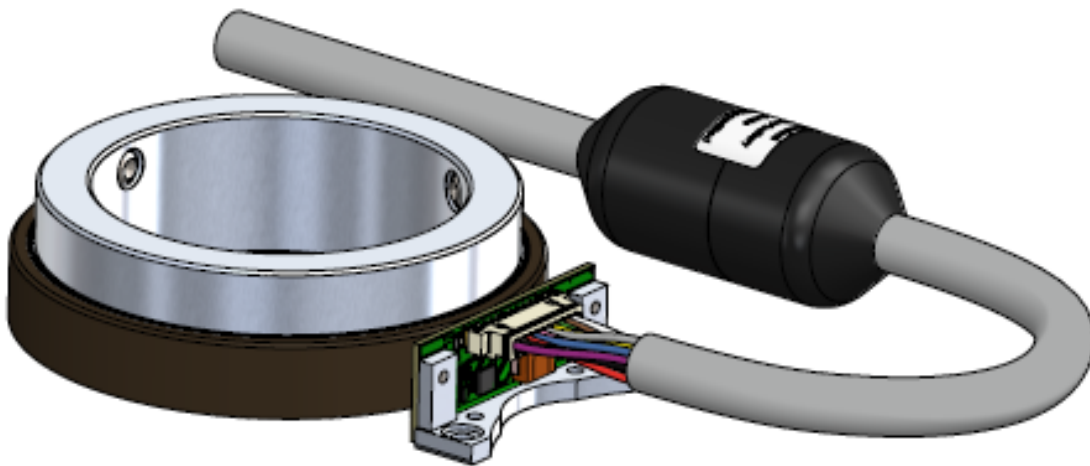

Features

- Resolution: Singleturn: up to 262,144 (**18 Bit**) steps per revolution
Multiturn: up to 16,777,216 (**24 Bit**) revolutions
- Resolution linear (step size): up to 4µm
- Interface: **SSI** (synchron serial interface) or **BiSS** (bidirectional serial synchron)
- Rotation speed: up to **25.000 rpm**
- Linear speed: up to **50m/s**
Preset (for zero position)
- Error Monitoring
- Battery buffered



Description

The **IMEA** is an absolute magnetic multiturn encoder. It is a rotary/linear kit system consisting of a magnetic hub/scale and a sensor head (including the PCB and mounting bracket).

The **IMEA** is a reliable encoder with large hollow shafts which can be fixed quickly and easily onto different sizes of motor shafts.

The encoder is developed for absolute positioning, for motors with gearboxes, servo motors, torque motors and direct drives. The IMEA 64 is a real time system for rough environments.

The encoder is available with different interfaces: SSI or BiSS. The Power supply is 5V and the signals are provided by a Molex connector or cable.

The backup battery is mandatory for the absolute position. The battery can be integrated in the encoder, in the cable or in the control unit.

The capacity of the backup battery determines the service life of the encoder. Up to 24 years can be achieved.

Main characteristics

- Absolute rotary encoder
- Magnetic sensing
- Multiturn by electronic gear
- Hollow shaft / linear encoder
- High performance in compact size
- Robust for rough environment
- Quick and easy assembly
- Several shaft diameter options
- Operating temperature range -40 °C to +85 °C
- Compliant EU-directive 2011/65/EU (RoHS)

Direction of rotation

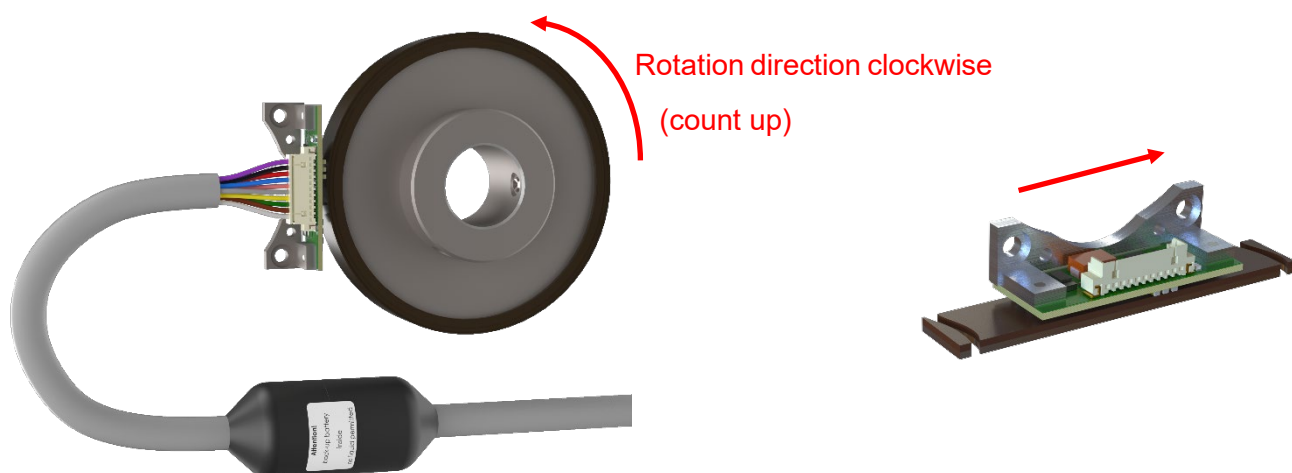

Dimensions (rotary)

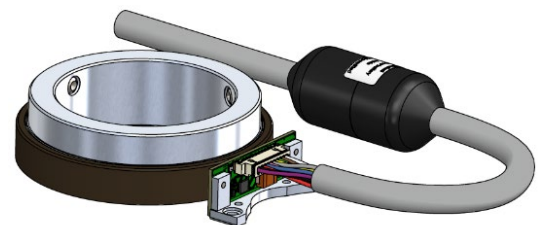
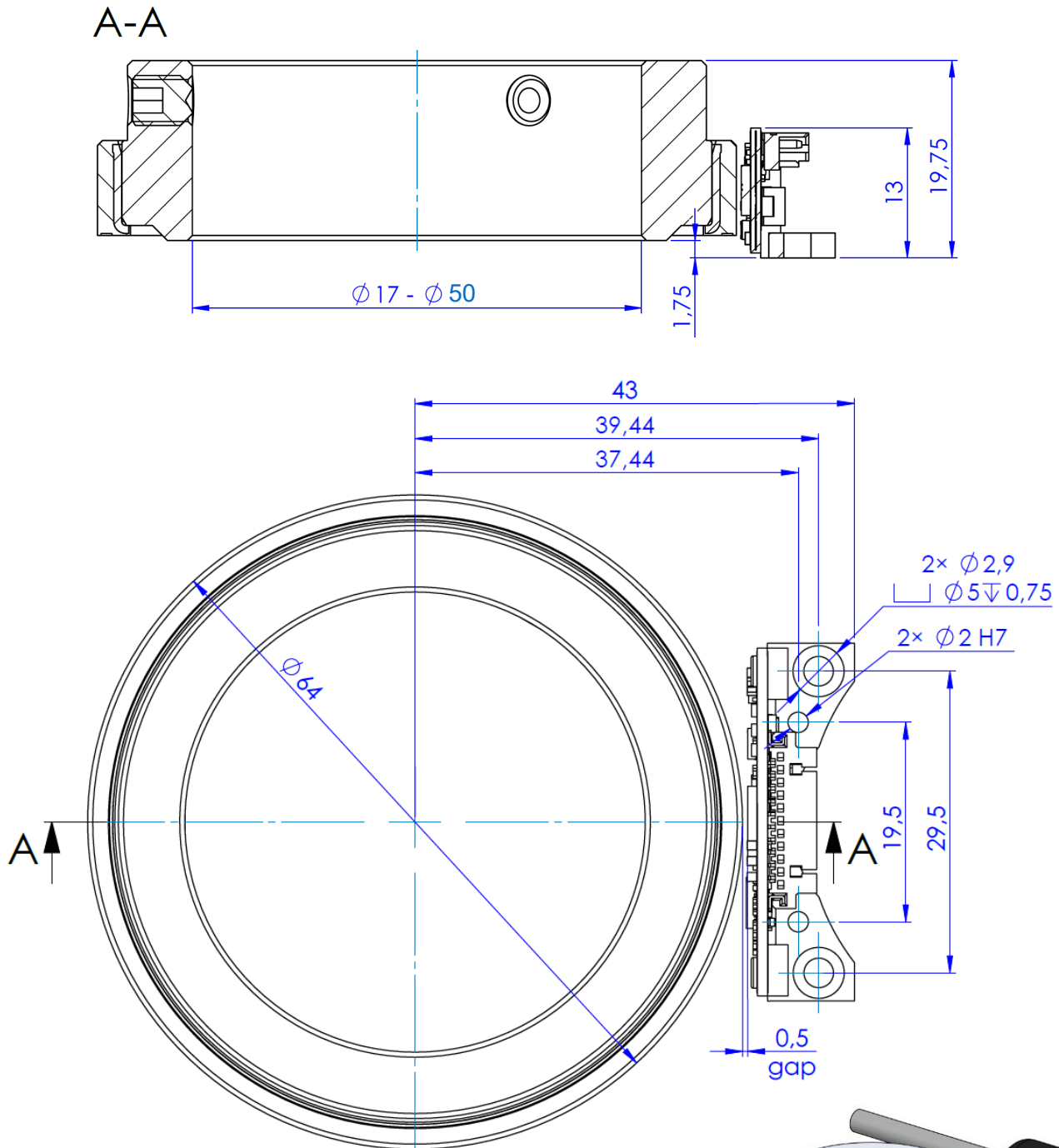

Dimensions (linear)

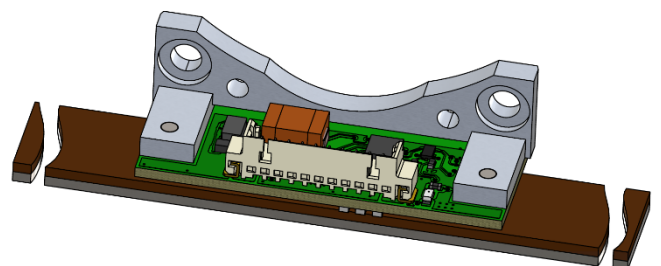
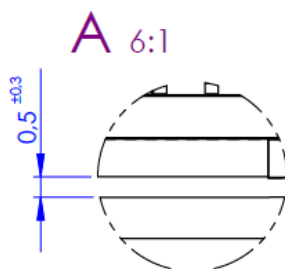
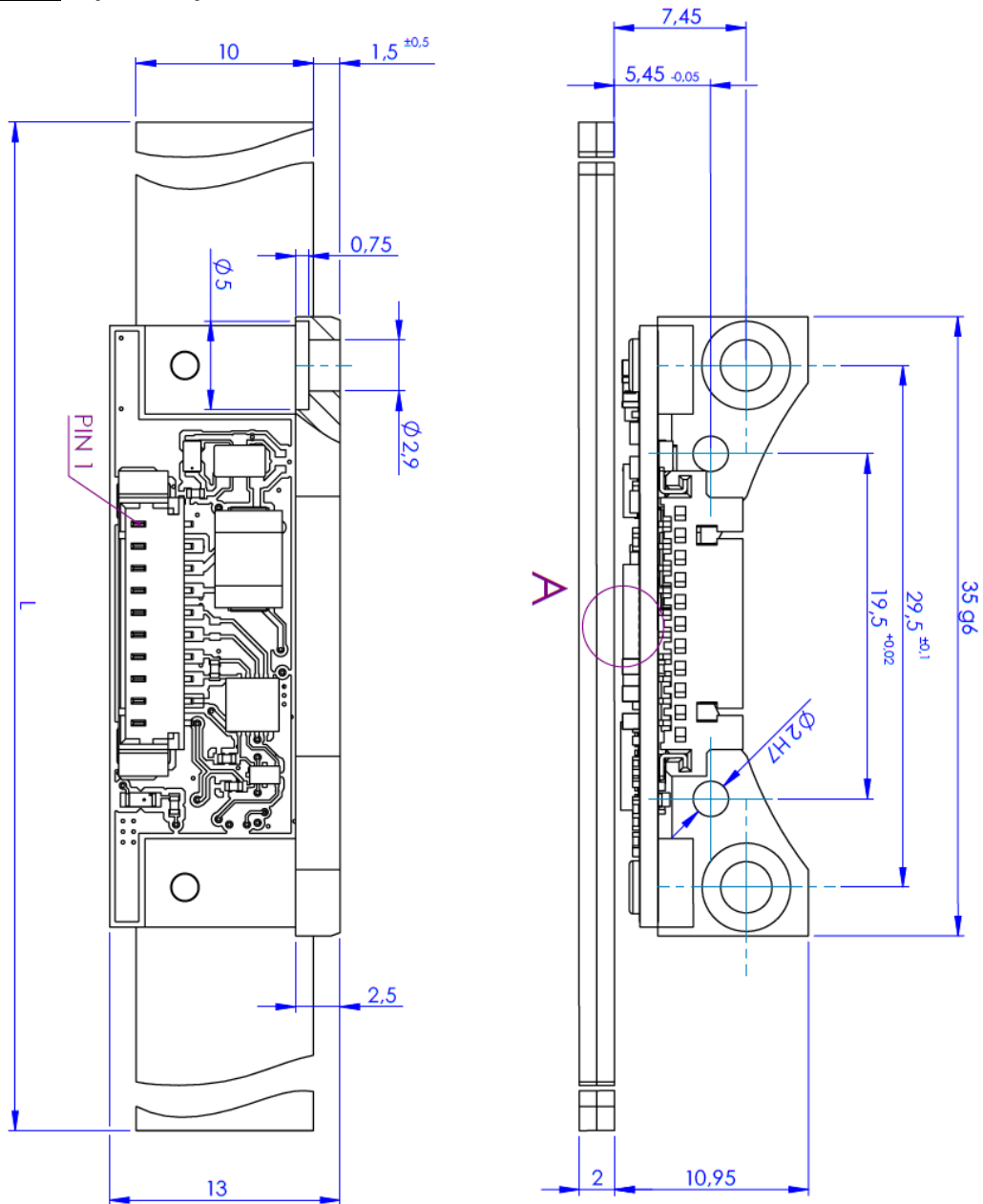

Recommended operating conditions

Typical values at 25 °C.

Parameter	Symbol	Min.	Typ.	Max.	Unit	Notes
Supply voltage	U_B	4.75	5.0	5.25	V_{DC}	
Supply current	I_{UB}	80	100	120	mA	no load
Reverse polarity protection	U_B	-6			V_{DC}	
Start up time	t_T			2	ms	
Absolute accuracy			+/- 0.07°			
Relative accuracy			+/- 0.01			
Rotation speed	RPM			25,000	rpm	
Acceleration	α_{max}			160	$10^{30}/s^2$	
ESD voltage	U_{ESD}			2	kV	discharged over 1,5k Ω
SSI/ BiSS						
Clock frequency	f	80		5000	kHz	
Scanratio of T		40	50	60	%	
Monoflop time	t_m		T/2		μs	adaptive Encoder Timeout
High level output voltage	V_{oH}	2.0	3.0	5.5	V_{DC}	$R_L = 120\Omega$
Low level output voltage	V_{oL}			0.8	V_{DC}	$R_L = 120\Omega$
High level input voltage	V_{iH}	2.0		5.5	V_{DC}	
Low level input voltage	V_{iL}			0.8	V_{DC}	
Output current per channel	I_{out}	-1.0	30	50	mA	overload protection
BiSS						
CRC Polynomial			0x43		hex	$x^6 + x^1 + x^0$
CRC Start Value			0x0000		hex	
CRC Bits			6			
CDM						inverted
Environment						
Operating temperature	T_A	-40	25	85	°C	
Storage temperature	T_S	-40		85	°C	
Humidity exposure				90	%RH	not condensing
Vibration				2000	Hz	20g
Backup battery						
Supply voltage	U_{Batt}	3.3	3.6	5.0	V_{DC}	
Warning voltage	U_{Warn}		3.2		V_{DC}	
Error voltage	U_{Err}		3.1		V_{DC}	

Mechanical characteristics and drawings

Parameter	Value	Tolerance	Unit
Magnet wheel outer diameter Ø	64.0	±0.1	mm
Shaft diameter Øw	17 / 50 *	±0.01	mm
Magnetic tape length	500 / 1,000 / 2,000 / 3,000 *	±1.0	mm
Permissible radial displacement	0	±0.15	mm
Permissible tangential displacement	0	±0.15	mm
Permissible axial displacement	0	±0.3	mm
Permissible eccentricity	0	±0.15	mm
Sensor to magnet wheel distance	0.5	±0.3	mm
Moment of inertia of the magnet wheel	20.0	±1.0	gmm ²
Mounting screw size	M 2.5 x 6	-	-
Tightening torque of the screws	30	-5	Ncm
Permissible rotational speed	25.000	-	rpm
Dimension PCB	35 x 13 x 11 (see Page 4)	-	rpm
Total weight	25	-	g
Protection grade according to DIN 40500	IP00 (according to DIN 40500)	-	-

Note: * Further shaft diameters or tape length on request

The maximum specified angular accuracy of the encoder can only be achieved with ideal mounting.

Pin out description SSI & BiSS

Connector Pin	Connector Signal
1	Backup +
2	UB
3	GND
4	Data +
5	Data -
6	Clock -
7	Clock +
8	Backup -

PCB connector:
Molex 53048-0810

Connector Signal	Cable color of wire
Backup +	red
UB	green
GND	blue
Data +	purple
Data -	brown
Clock -	yellow
Clock +	orange
Backup -	black

Standard cable 0300
without backup

Cable Signal	Cable color of wire
UB	red
GND	blue
Data +	pink
Data -	grey
Clock +	green
Clock -	yellow

Standard cable 05Bx
with backup

Interface:

Data transfer: SSI

Binary-Code

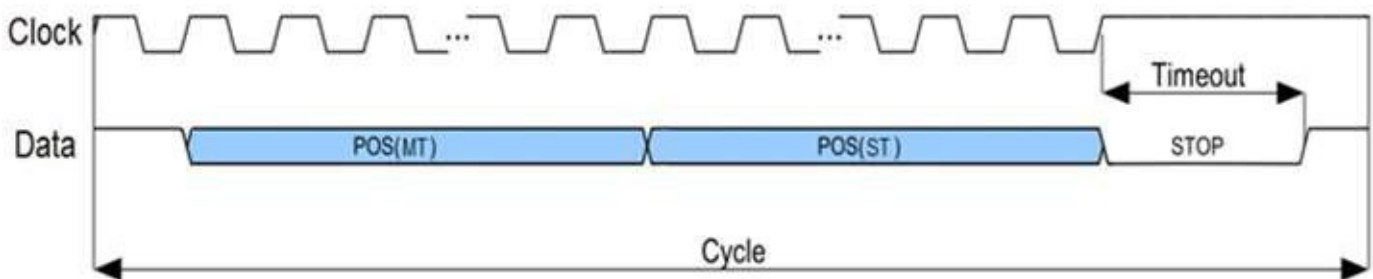

The position data increases when the shaft rotates in the direction of clockwise

Data transfer: BiSS (C-Mode)

Binary-Code

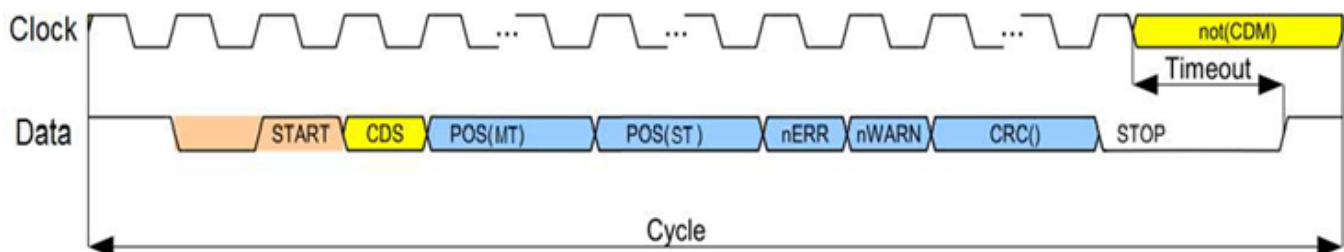

The position data increases when the shaft rotates in the direction of clockwise

For a detailed description of the protocol, see separate interface specification.

Preset is programmable by a BiSS command.

Error monitoring is also controlled via the BiSS interface.

Ordering code - Rotary:

IMEA 64 R - XX - XXX - X - XX / YY - 05 - XXXX - X

Outer diameter	Encoder Type	Inner diameter	Design	Encoder Interface	Resolution	Cable / Backup **	Performance
64	R: Radial	17: 17mm 50: 50mm	Y01: Bracket Y03: PCB* Y02: Housing*	S: SSI B: BiSS	Singleturn XX: 12: 12 Bit 16: 16 Bit 18: 18 Bit Multiturn YY: 00: None 16: 16 Bit 24: 24 Bit	05B1: 0.5m/1Ah 05B4: 0.5m/4Ah 05B7: 0.5m/7Ah 0300: 0.3mm/-	S: Standard E: Extended *

* Optional (customer-specific)

** Backup lifetime (Basis of calculation: Additional document PWB):

- 1Ah ≈ 3.5 years Ø 20 mm
- 4Ah ≈ 10 years Ø 23 mm
- 7Ah ≈ 17 years Ø 31 mm
- 13Ah ≈ 24 years Ø 39 mm

The backup battery voltage is permanently monitored. If the voltage is too low, a warning is displayed (in the data string). However, the function is still guaranteed.

If the backup system is out of function, the error bit is set.

IMPORTANT NOTICE

The guarantee will be voided by misuse, accident, modification, unsuitable physical or operating environment, operation in other than the specified operating environment, or failure caused by a product for which **PWB encoders GmbH** is not responsible.

PWB encoders GmbH reserves the right to make corrections, modifications, enhancements, improvements, and other changes to its products and services also datasheets at any time.

Ordering code - Linear:

IMEA XXX L - XX – XXX - X - XX - 05 - XXXX - X

Mag. tape length	Encoder Type	Mag. tape width	Design	Encoder Interface	Resolution (step width)	Cable / Backup **	Performance
500 mm	L: Linear	10: 10mm	Y01: Bracket	S: SSI	04: 4 µm	05B1: 0.5m/1Ah	S: Standard
1,000 mm			Y03: PCB*	B: BiSS	08: 8 µm	05B4: 0.5m/4Ah	E: Extended *
2,000 mm			Y02: Housing*		25: 25 µm	05B7: 0.5m/7Ah	
3,000 mm					50: 50 µm	0300: 0.3mm/-	

* Optional (customer-specific)

** Backup lifetime (Basis of calculation: Additional document PWB):

- 1Ah ≈ 3.5 years Ø 20 mm
- 4Ah ≈ 10 years Ø 23 mm
- 7Ah ≈ 17 years Ø 31 mm
- 13Ah ≈ 24 years Ø 39 mm

The backup battery voltage is permanently monitored. If the voltage is too low, a warning is displayed (in the data string). However, the function is still guaranteed.

If the backup system is out of function, the error bit is set.

IMPORTANT NOTICE

The guarantee will be voided by misuse, accident, modification, unsuitable physical or operating environment, operation in other than the specified operating environment, or failure caused by a product for which **PWB encoders GmbH** is not responsible.

PWB encoders GmbH reserves the right to make corrections, modifications, enhancements, improvements, and other changes to its products and services also datasheets at any time.

Standard cable 05B1

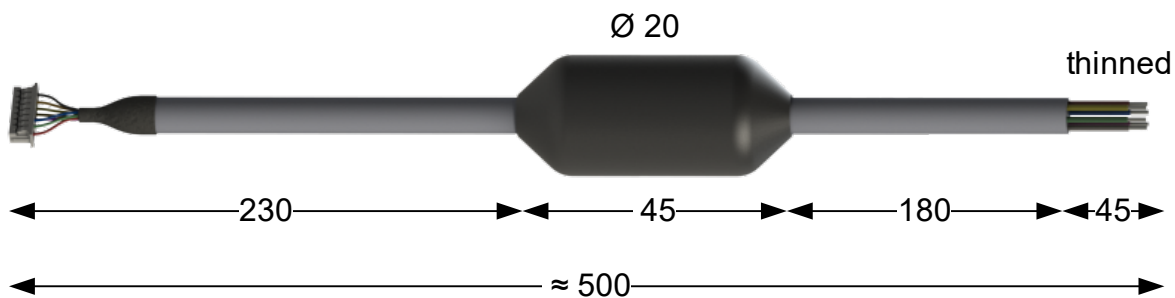

Attention!
Backup battery inside
No liquid permitted

Cable 0300

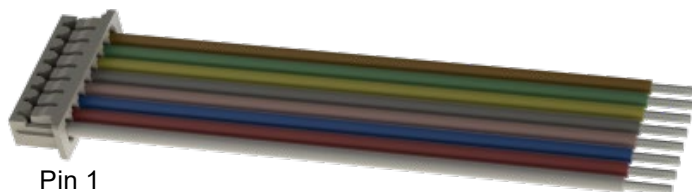

Cable without backup (length 300 mm)
[for applications with backup on customer control]

Accessories

For communication with the IMEA 64, a USB converter box (PWB5C) is available from PWB encoders. The software is available from PWB on request. The software can help for the first use and for visualization of the position data. It is not necessary for operation in the customer application with the customer control.



PWB encoders GmbH RESTRICTED

THIS DOCUMENT AND ANY ASSOCIATED DATA CONTAIN RESTRICTED INFORMATION THAT IS PROPERTY OF PWB encoders GmbH AND MAY NOT BE DISCLOSED OR DUPLICATED FOR OTHERS EXCEPT AS AUTHORIZED BY PWB encoders GmbH

INFORMATION CONTAINED IN THIS PUBLICATION MAY BE SUPERSEDED BY UPDATES. IT IS YOUR RESPONSIBILITY TO ENSURE THAT YOUR APPLICATION MEETS WITH YOUR SPECIFICATIONS.

Installation and commissioning instructions

Mounting and Connection Sequence

- Mounting the magnetic wheel
 - ⇒ Check the correct position. Fix in position
- Position the PCB (or the PCB with metal holder)
 - ⇒ Check the correct air gap. Fix in position
- Connect the cable to the PCB (do not reverse the sequence).
- Connect the cable to the control unit
- Electrical commissioning

When connecting the cable to the PCB, a magnetic field must be present from the magnetic wheel. (The cable must not be connected to the PCB beforehand. Otherwise, malfunctions may occur)

Error behavior and error states

Error state: Magnetic field too weak (LED error indicator on the PCB or via SW)

Cause: The applied magnetic field falls below the specified minimum field strength (e.g., air gap too large, incorrect magnet, or incorrect alignment).

Error indicator: The error condition is signaled by a red LED on the circuit board. As soon as the red LED is active, the minimum magnetic field strength has not been reached.

Error behavior: The error condition remains active as long as the minimum magnetic field strength is not reached.

Resetting the error: The error condition can only be reset when the encoder is fully assembled. To do this, the connection cable (including battery) must be disconnected from the PCB.

The error state can only be cleared after the power supply (VCC and battery) has been completely disconnected and then reconnected (VCC including the battery voltage).